

OIL ON WATER MONITOR (Non Explosion Proof Version)

Model: ODL-1600

The Model ODL-1600 monitors a water surface for the presence of an oil film floating on the surface. The instrument projects a laser beam onto the water surface and measures the differences in the reflection properties between water and oil.

This model is the most recent in a series of oil on water monitors. These have been field proven over decades and are used in a wide variety of installations worldwide. These instruments include the Models ODL-12 and ODL-20.

The design of the model ODL-1600 is the result of decades real world experience and features many new enhancements including faster signal processing, improved optical design and continuous scanning laser system. These design enhancements enable the Model ODL-1600 to offer improved oil detection even for non-ideal water surfaces such as those with bubbles present.

This model complements our existing range. If installation in hazardous areas is required, we recommend our intrinsically safe Model SODL-20 version. The Model SODL-20 has official certification showing compliance with the relevant IEC standards. Please refer to a separate specification sheet for information on this particular version.



Features

- Non contact detection system.
- Scanning laser beam system provides enhanced detection even under difficult surface conditions such as the presence of floating debris, bubbles or curved oil surfaces.
- Scanning system contains no moving parts reducing power consumption and increasing reliability.
- Fast signal processing and short pulse cycle of laser beam provides excellent detection ability even on water surfaces with ripples and waves.
- Internal micro-computer provides comprehensive diagnostic and maintenance information including reflected light intensity, oil detection history etc..
- The instrument is also capable of detecting leakage of water or oil on dry surfaces.
- Enhanced optical design enables mounting of the detector from 0.3m up to 3m from the water surface (mounting up to 5m is possible for smooth water surfaces).
- Rugged, cast aluminium enclosures suitable for mounting in harsh, industrial environments.
- Simple, easy to adjust mounting brackets allow easy installation and maintenance.
- A single transmitter can control up to two detectors (optional).

Specifications

Product Name:	Oil on Water Monitor (non explosion proof version)
Model Code:	ODL-1600
Measurement Object:	Oil slick floating on water surface or dry surface (floor)
Measurement Method:	Reflectance of visible light
Sensor Distance:	0.3m ~ 3m above water or floor surface (0.3m ~ 5m for smooth water surfaces - for example located indoors)
Light Source:	Class 2 semiconductor laser diode (red)
Configuration:	Detector and transmitter housed in separate enclosures.
Ingress Protection:	IP-65
Ambient Conditions:	Temperature: -10 ~ 50 deg C Humidity: 5-95% RH
Sample Temperature:	No freezing
Output Signals:	4 ~ 20mA max load 600 Ohms (additional alarm status selectable). It is also possible to set analogue output to ODL-20 compatibility mode (normal conditions: 18mA, oil detected 20mA, instrument malfunction 16mA).
Contact Switching Output Signals:	Total 6 contacts available ("a" contact x 5, "c" contact x 1) Oil alarm, under maintenance (ST BY mode setting), Detection error (water surface detection error, reflected light error, ambient light error), Instrument error (laser output error, internal temperature error) power failure (selectable closed or open during power failure) Contact Rating: 30VDC, 0.1A

Digital Communication System:	- Based on RS-485 (isolated) - Available Baud rates: 2400, 4800, 9600, 19200, 38400, 57600 - Protocol: MODBUS/RTU - Data length: 8 bits - Parity: select from None, Odd, Even - Stop bits: 1 Bit - Data Order: Big Endian
Operating Power:	100~240 VAC +/- 10%, 50/60 Hz
Power Consumption:	Approx. 10VA (normal), approx. 15VA (max). When optional heater is installed consumption will be approx. 30VA.
Weight:	- Transmitter: approx. 2.2 kg - Detector section: approx. 14 kg
External Dimensions:	- Transmitter: approx. 181 (w) x 180 (h) x 95 (d) (mm) - Detector: approx. 240 (diameter) x 443 (l) (mm)
Construction Materials:	Transmitter: die cast aluminium Detector: die cast aluminium
Surface Finish:	Metallic silver
Electrical Connections:	- Transmitter: Six cable glands for 6~12mm diameter cable, G1/2 threaded connections when gland removed. - Detector: Two cable glands for 6~12mm diameter cable, G1/2 threaded connections when gland removed.
Connecting Cable Lengths:	- Transmitter to detector: max 100m (power and communication cable) - Transmitter to receiving device: max 100m (digital communication)

Principle of Operation

The reflectance of light from an oil film is greater than that of water. When an oil film is present on a water surface, it generates a "glistening" effect. From this property, the presence of oil can be detected by applying a light beam of constant intensity to the water surface and then measuring the intensity of the reflected light.

The detector contains a semiconductor laser diode, a laser scanner and a photodiode light sensor. The light output from the laser tube is scanned across the water surface periodically

across the x-y axis. The light that is reflected back by the water surface is captured by a parabolic mirror and focused on to a sensor located at the focal point of the mirror.

The signal from the light sensor is processed by the micro electronics in the transmitter. From the processed signal it can be determined whether an oil film is present or not. The transmitter provides output signals indicating the detection status such as contact switching signals, analogue signals etc..

Water Level Height Variation

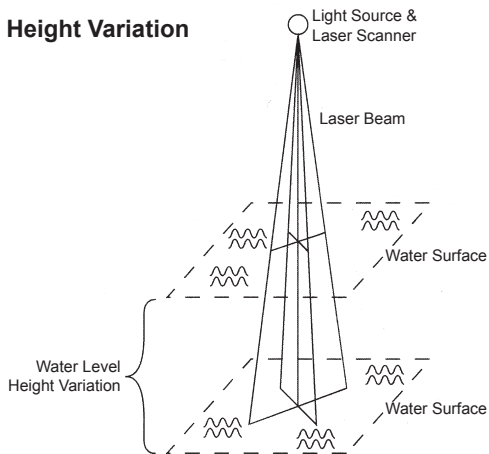

Mirror & Light Sensor

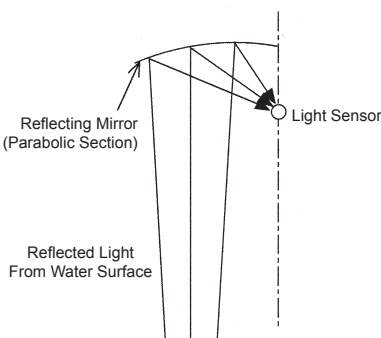

System Configuration

The instrument comprises a detector and transmitter. The detector and transmitter continuously communicate. The raw detection signal and diagnostic information are sent from the detector to the transmitter. The transmitter provides local status display and generates output signals for onward transmission to an external plant control system or external receiving device. The transmitter allows set up of operating parameters such as detection mode and alarm settings etc.. As an option, two detectors can share a single transmitter. In this configuration the transmitter communicates with each detector individually and provides individual alarm and analogue output signals corresponding to each detector. (max 6 contact switching points).

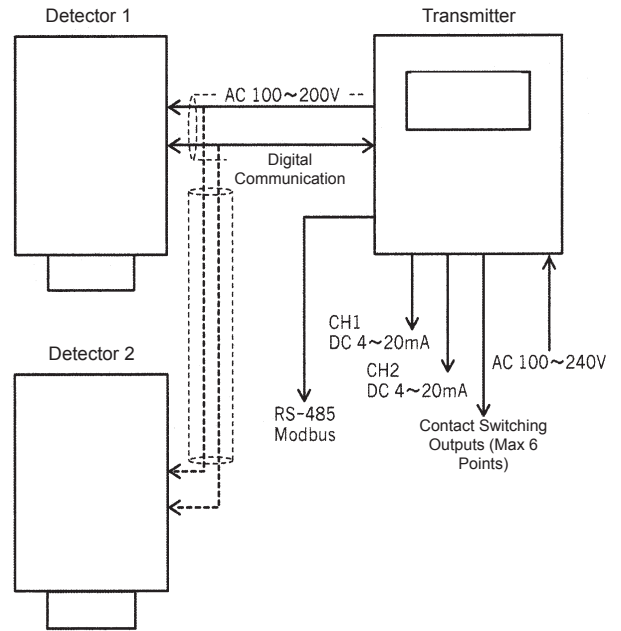

Transmitter Functions

(1) Display

The transmitter displays information on calibration, oil film detection status, raw light intensity, self-diagnostics and error conditions.

(2) Oil Detection Modes

The transmitter allows the detector to be set up for particular water surface conditions such as still, smooth surfaces or unstable surfaces with waves and bubbles etc.. The transmitter allows the operator to establish a suitable set up for the particular installation conditions.

(3) Analogue Output Signals

A 4-20mA output signal is available representing the light intensity signal. As an additional function, the analogue output can also be set to indicate alarm status of the instrument (oil detection, instrument malfunction). It does this by changing the analyser output to an out of scale value (21mA, 3mA). Thus a single analogue signal can transmit three detection conditions (normal operation with raw intensity signal, instrument malfunction and oil alarm)

(4) Contact Switching Output Signals

A total of six contact switching signal are available. These can be configured by the operator to represent alarm and self diagnostic information. The available signals are as follows:-

- Oil film detection.
- Under maintenance (ST-BY mode).
- Detection error (water surface detection error, reflected light error, ambient light error).
- Instrument malfunction (laser output trouble, internal temperature alarm).
- Power failure (open or closed contact available).

(5) External Device Communication

Digital communication with external devices is available using MODBUS protocol from the RS485 output signal.

(6) Optional Dual Detector Capability

It is possible to connect two detectors to a single transmitter enabling the monitoring of two different locations simultaneously.

(7) Detection History Stored in Memory

Detection parameters are stored in memory together with date and time of detection. This data can be re-called by the operator. The historical data can be used to evaluate instrument performance and assist in fine tuning the sensitivity set-up etc..

Terminal Connections

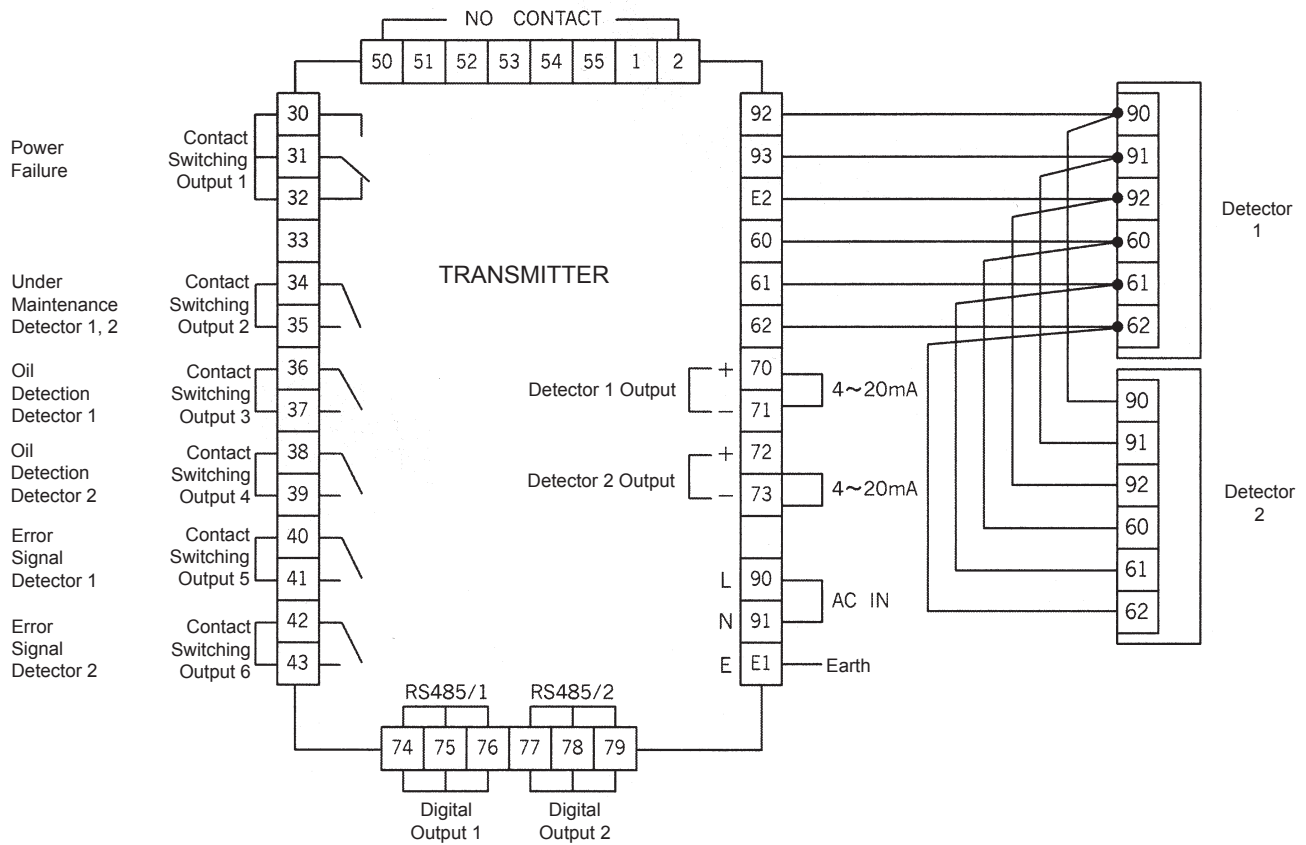

Detector 2 Connects to Terminals of Detector 1

Dimensions

(Units: mm)

• Transmitter

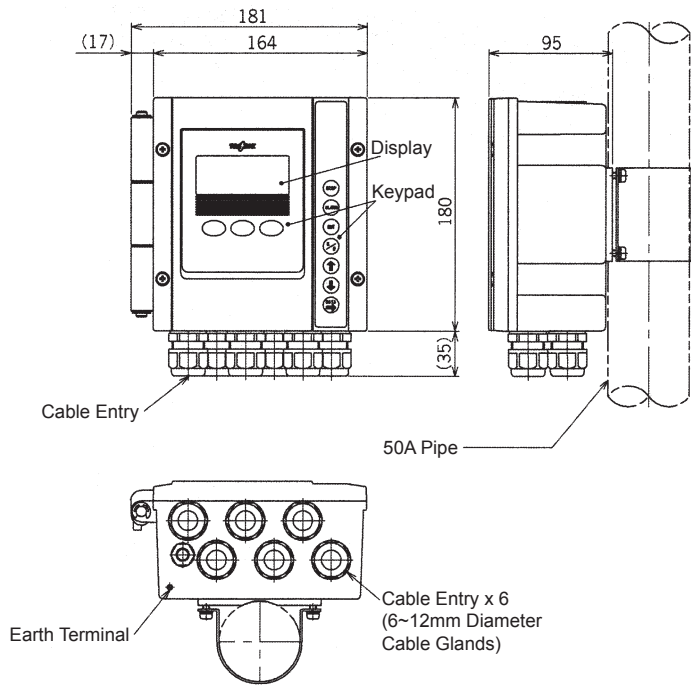

• Detector

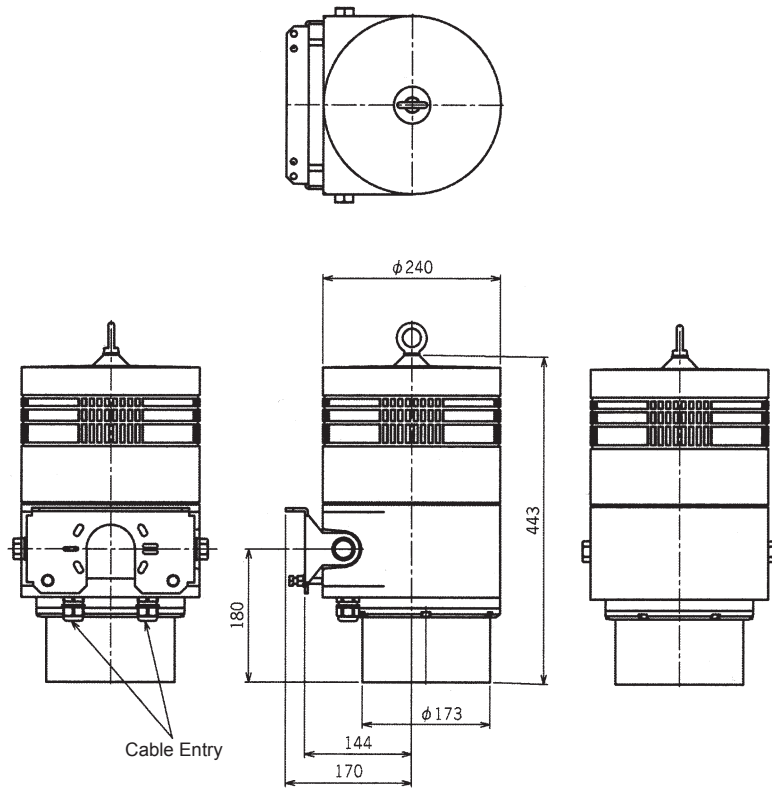

Installation

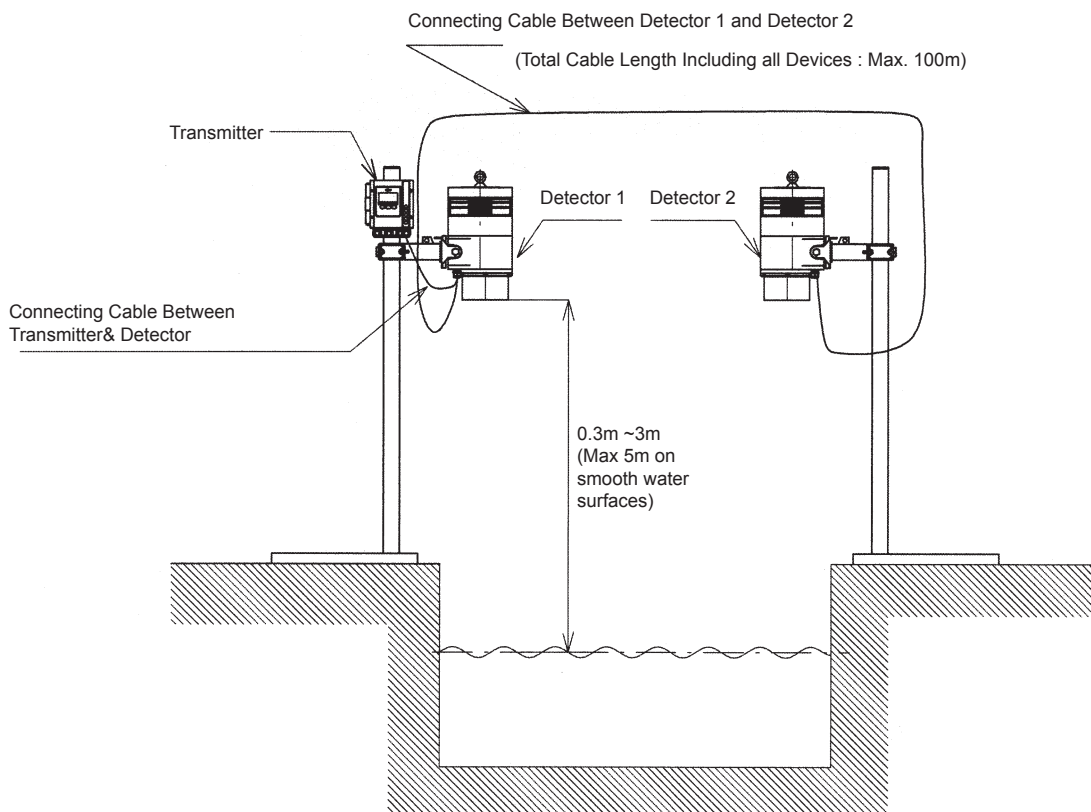

Installation Conditions

- (1)**

The detector should be mounted within 0.3m to 3m from the water surface for normal water conditions. In ideal conditions (for example smooth water surfaces located indoors) the distance can be increased to within 0.3m to 5m. When evaluating installation locations consider water level changes, these must be within the distances given above. Avoid mounting too close to the water surface in order to avoid splashing and potential damage due to immersion during unexpected flooding, heavy rain, etc..
- (2)**

Install the analyser at a location where the water flows smoothly. Avoid locations where there is turbulence.
- (3)**

Install the analyser at the location where the monitoring surface will not be subjected to direct rainfall or direct wind disturbance, because a severely rippled water surface may make it difficult for oil film detection. For such locations, protection against direct rainfall or wind disturbance will be required.
- (4)**

Avoid installing the detector in locations where dead leaves or other debris may accumulate on the water surface. These may affect water flow characteristics and cause detection problems.
- (5)**

Avoid locations where sunlight may disturb detection. If strong sunlight causes detection problems, move the detector to a shady location or install a sun shade.
- (6)**

Strong, direct sunlight may cause high temperatures inside the instrument enclosures. When the instrument is installed in locations subject to strong sunlight, protect with an appropriate sun-shade.
- (7)**

Install the instrument in a location where vibrations and mechanical shocks are minimised. Secure a space around the analyser and scaffolding if necessary for a safe and easy access during maintenance.
- (8)**

Avoid locations where there is rising mist due to high water temperature. If this is unavoidable, supplying a gentle airflow will effectively clear the vapour away.
- (9)**

If using the instrument to monitor liquid leakage on dry surfaces (such as floors etc.), ensure that the surface is level. A sloping surface will not reflect the light from the laser beam correctly and cause detection problems. Select a part of the surface where any leaked liquid will form a smooth liquid film. If the dry surface is excessively shiny, place a non-reflective surface over it such as a rubber mat etc..

Product Code

ODL1600-0-	<input type="checkbox"/>	<input type="checkbox"/>	<input type="checkbox"/>	<input type="checkbox"/>	<input type="checkbox"/>	<input type="checkbox"/>	<input type="checkbox"/>	<input type="checkbox"/>	<input type="checkbox"/>																															
	0	1	0	1	1	2	3	4	8	0	1	2	3	4	8	A	B	C	D	1	2	0	1	2	0	1	2	3	0	1	2	3	4	5	6	A	B			
	Transmitter Mounting		Number of Detectors Connected		Cable Length from Transmitter to Detector		Cable Length from Detector 1 to Detector 2 *1		Anti Misting Heater for Detector Glass *2		Mounting Bracket for Detector 1		Mounting Bracket for Detector 2		Hood (for Preventing Interference from Mist or Steam)		Sun Shade		Markings																					
	On a 50A pole		One (Detector 1)		2m (standard)		None (in case of only one detector)		None		For Mounting on 50A pole (Pole available as an option)		None (in case of only one detector)		None		None		Standard (Japanese Language)																					
	Wall or rack mounting		Two (Detectors 1 and Detector 2)		10m		2m		Equipped to Detector 1 only		For Replacement of ODL-12 or ODL-20 etc.) *3		For mounting on 50A pole (pole available as an option)		Equipped to Detector 1 only *4		Equipped to Transmitter Only		English Language																					
					20m		10m		Equipped to Detector 2 only				For replacement of ODL-12 or ODL-20 etc.) *3		Equipped to Detector 2 only *4		Equipped to Detector 1 only																							
					100m		20m		Equipped to both Detectors 1 and 2						Equipped to both Detectors 1 and 2 *4		Equipped to Detector 2 only																							
					Custom specification (max 100m)		98m		Custom specification (max 98m)						Equipped to both Detectors 1 and 2 *4		Equipped to both Detectors 1 and 2																							

Note 1:

The maximum total cable length between transmitter, detector 1 and detector 2 is 100m (i.e. if cable length from detector 1 to detector 2 is 98m then max cable length from transmitter to detector 1 is 2m. Cable lengths are specified in 1m increments. Detector 2 must connect to terminals of Detector 1. Detector 2 should not connect directly to the Transmitter.

Note 2:

An anti-misting heater for the detector glass is recommended. Select "equipped" if the installation location is prone to sudden temperature changes from low to high and/or the location is subject to high humidity. For example a heater would be required if the temperature changes from 10 Deg C to 25 deg C within 30 minutes and ambient humidity is 90%.

Note 3:

If replacing existing Model ODL-12 or ODL-20 instruments, it is necessary to check types of existing fitting brackets and also analogue and alarm signals. Changes may be required to accommodate the new instrument - please consult with your local sales office or distributor.

Note 4:

If the water surface generates steam or mist, an optional hood may be required. The hood design is dependent on distance of detector from the water surface. Instrument air supply is also required if a hood is selected as "equipped".

- The instrument operates on multi-voltage supply of 100 to 240 VAC.
- Analogue output is 4-20mA.
- A mounting pole (B-150, 304 series stainless steel) is available as an optional item.

Dimensions

(Units: mm)

- **Optional Adapter**

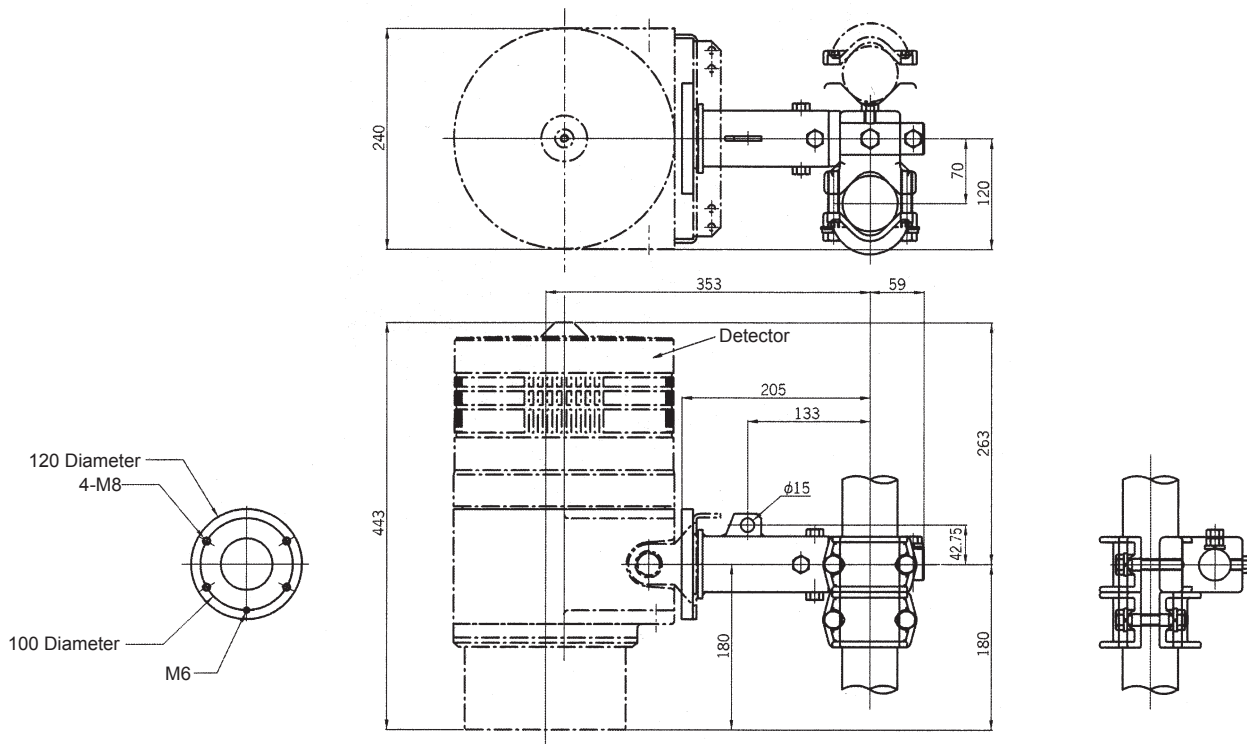

Always read the instruction manual before operation.

Due to continuous product improvement, specifications contained herein are subject to change without notice.

International Operations:

DKK-TOA Corporation
 29-10, 1-Chome, Takadanobaba, Shinjuku-ku, Tokyo 169-8648 Japan
 Tel: +81-(0)3-3202-0225 Fax: +81-(0)3-3202-5685

Representative Office (Europe):

DKK-TOA European Representative
 St. Johns Innovation Centre, Cowley Rd., Cambridge CB4 0WS UK.
 Tel : +44 (0)1223-526471 Fax : +44 (0)1223-709239

www.dkktoa.net www.toadkk.co.jp

Local Representative: